

<b><i>WABO/SEAW</i></b> <b><i>Liaison Committee</i></b> Washington Association of Building Officials & Structural Engineers Association of Washington	<b>WHITE PAPER 9-2020</b>
--	---------------------------

<b>Title:</b> Threaded Rod Holdown Systems In Wood Frame Buildings	<b>Dated:</b> March 7, 2013 <b>Issue Date:</b> June 30, 2020 <sup>1</sup>
<b>Abstract:</b>  This white paper establishes guidelines for specifications for building officials, design professionals, contractors and building owners relating to threaded rod holdown systems and associated anchorage of shear walls in wood frame buildings.	<b>Committee Members:</b> <i>Matt Snook (SEAW Co-chair), Lee Kranz (WABO Co-Chair), Shalini Prochazka (SEAW), Nancy Devine (WABO), Larry Lindell (SEAW), Rick Fine (SEAW), Mary Kate McGee (WABO), Cheryl Burwell (WABO), Chris Ricketts (WABO), Steve Belzak (WABO), Charlie Griffes (SEAW).</i>
<b>Committee Mission Statement:</b> <ul style="list-style-type: none"><li>• <i>Improve communications between the public jurisdictions that administer building codes and the engineering design community that prepares construction documents.</i></li><li>• <i>Improve consistency and quality of engineering submittals and project reviews.</i></li><li>• <i>Build consensus between the engineering design community and building officials with regard to code interpretation and submittal requirements.</i></li></ul>	

<sup>1</sup>Appendix A added by members of the 2020 committee.

## I. Introduction

Modern wood framed multi-story buildings often employ continuous threaded rod holdown systems to resist overturning forces in shear walls. The design of such systems is governed by IBC and ACI 318. This white paper will provide recommendations and guidelines for specifying threaded rod systems including the holdown anchor design in concrete.

## II. Threaded Rod Holdown Specific System Specification

The Engineer of Record (EOR) can provide performance criteria for a holdown system supplier or may directly specify a holdown system and all of the associated system components. Shrinkage compensating devices are often included in the design of four or more stories and must have a current approved evaluation report.

For performance criteria, the following list of items must be provided on the plans:

1. Cumulative tension loads per story.
2. Compression loads per story, including lumber grade and story wall heights.
3. Building shrinkage and consolidation allowances per story to determine the amount of travel required by the shrinkage compensating devices.
4. Plan view locations of holdowns.
5. Rod system deformation limit (if required).
6. A requirement for the holddown submittal to be stamped by a registered design professional.

For holdown specific system criteria, the following list of items must be provided on the plans:

1. Specify the holddown system and approved alternates.
2. Specify rod diameters and steel material grade.
3. Specify bearing plate requirements.
4. Specify compression posting.
5. Specify shrinkage devices and couplers.
6. Plan view locations of holdowns.
7. Rod system deformation limit (if required).

### **III. Anchor Design in Concrete Considerations**

It is strongly recommended that the EOR provide the design of all anchors in concrete. This should not be a part of a deferred submittal. ACI 318 Chapter 17 provides the applicable seismic design requirements for the holddown anchorage of wood frame shear walls. The following list of items should be included in the design and shown on the drawings:

1. Anchor rod diameter and material grade.
2. Concrete strength.
3. Required anchor embedment depth including standoff distance or concrete cover.
4. Minimum anchor distance from edges and corners.
5. Reinforcement details for edge, corner and anchor group effects, as required.

## **COMMENTARY**

### **C-II. Holdown Specific System Specification**

In four story structures and taller, the cumulative holddown forces and deformations will exceed the capabilities of standard conventional holddown connectors and straps. Threaded rod systems offer much higher design capacities and can provide for shrinkage compensation and building consolidation. Shrinkage compensators (or take-up devices) help eliminate loose connections for better shear wall performance.

**Building Shrinkage Estimation:** An estimate of dimensional change in wood due to shrinkage per story is required in order for the rod system supplier to determine the amount of travel required for their take-up device components. Shrinkage may be calculated on each project or a typical value may be used for buildings having similar construction and similar initial moisture content in the lumber.

Estimation of wood shrinkage should account for the following:

- a) **Moisture content ("MC").** Consider the difference of initial MC to equilibrium MC of the region.
- b) **Building materials.** Consider sawn lumber floor joists vs I-joists and the wood species used on the project.
- c) **Framing methods.** Consider balloon or platform framing, floor joists resting or hanging on wall, etc.

**Building Consolidation Estimation:** Building consolidation or settlement is due to small gaps that occur between plates and studs, caused by items such as mis-cuts (short studs) and the lack of square-cut ends. These gaps can typically account for up to 1/8 inch per story. Installed lumber that is warped, bent or twisted may also contribute to this amount of settlement.

**Combined Shrinkage and Consolidation Amount:** An estimate for total shrinkage and consolidation for a typical story wall is 1/4 to 1/2 inch per floor<sup>1</sup>.

#### **Performance Based vs Holdown Specific System Criteria:**

This document provides a guide for the use of performance criteria or holdown specific system criteria. The engineer should check with the local building authority to verify if a holdown system may be a deferred submittal or if the components of a specific threaded rod system will need to be included for permit submittal.

For performance based criteria, it is recommended to show tension and compression loads in a consolidated multistory table format with the vertical "runs" defined. This will make it easier for both the rod system supplier to create the shop drawings and the engineer to check them. This table may include representative rod diameters with steel material grade requirements in lieu of tension forces.

For holdown specific system criteria, it is recommended that the EOR provide the specific system components on the structural plans to eliminate a deferred submittal. The engineer is encouraged to engage a specific rod system supplier to provide design assistance. Online design tools are available at no charge and will provide CAD details and calculations.

**Compression Stud/Post Design:** Basic design is referenced by code to use NDS. Design combinations are per ASCE 7 criteria. This includes the combination of dead and live loads with the seismic or wind loads. This will control the design of the compression studs.

**Building Drift.** Part of the overall building analysis and design criteria is to consider the code story drift limitations. The code limits this “story drift” to about 2½% of building story height up to four stories and 2% for five stories or higher per ASCE 7. There are two primary reasons for this consideration:

- a) Building separation.
- b) Damage to interior elements.

The calculation for building drift is critical and should be required if the new building is adjacent to another structure. There seems to be little evidence that story drift has been a significant problem in previous seismic events.

**Rod System Deformation Limit:** Effective April 2013, take-up device evaluation reports conforming to ICC AC 316 will require the rod system to have a total vertical deformation (that includes steel rod elongation and the shrinkage compensating device deflection) is less than or equal to 0.20 inch (5 mm) for each story, or between restraints, whichever is more restrictive, using allowable stress design (ASD). This vertical limit may be exceeded if the EOR can demonstrate the shear wall story drift limit and the deformation compatibility requirements of IBC Section 1604.4 are met when considering all sources of vertical displacement.

If drift calculations are required, the rod system deformation limit per story is required to be specified by the EOR for both performance based criteria and holdown system specific specifications.

**Shrinkage and Consolidation Amount in Drift Calculations:** Note that if a holdown system with shrinkage compensation is used, the amount of shrinkage and consolidation calculated per story should not be included in the four part drift equation. Conventional systems without shrinkage compensation will require these amounts to be included in drift analysis.

### **C-III. Anchor Design in Concrete Considerations**

Most wood frame walls are supported by concrete stem walls or concrete podium slabs. Anchorage to concrete is governed by ACI 318 Chapter 17. This is a relatively new portion of the code and not well understood by the design community. This has led some engineering firms to include the anchorage design as part of the “deferred submittal” package to be provided by the holdown system supplier. It is strongly recommended that the EOR design the anchorage in concrete prior to permit submittal. This may avoid a situation that is not code compliant and difficult or impossible to rectify. This would avoid creating scheduling and cost problems for the project due to the fact that there may be hidden costs for anchorage design and additional reinforcement. This will also impact the project schedule including increased time for building department review and construction cost.

## **Determining the Size of Rod for Anchorage to Concrete:**

In order to design the rod size and material grade for anchorage to concrete, the EOR must consider the following:

- a) Shear loads from wind/seismic criteria as resisted by the wall sheathing.
- b) These forces then create overturning moments based on shear wall length. These moments are resisted by uplift on the holdown system and compression on the studs at the ends of the wall.
- c) Stacked shear walls will have cumulative uplift and download forces.
- d) The anchor rod size does not necessarily need to match the size of the holdown system rod immediately above. There are designs where the holdown rod above the anchor is enlarged only to reduce elongation, not for strength. In these cases, the anchor rod may have adequate strength capacity in accordance with ACI 318 Chapter 17 and may not need to be enlarged to match the holdown rod diameter above.

## **References:**

- <sup>1</sup> Five-Story Wood-frame Structure over Concrete Podium Slab, Woodworks.org Design Example, March 2012, Douglas Thompson, PE, SE, SECB, STB Structural Engineers.  
<http://www.woodworks.org/wp-content/uploads/5-over-1-Design-Example.pdf>

*Thank you to the following original committee members for their contributions to this white paper: Mark D'Amato (SEAW), Charlie Griffes (SEAW), Lee Kranz (WABO), Chris Ricketts (WABO), Jon Siu (WABO), Rick Fine (SEAW), Larry Lindell (SEAW), Mary Kate Martin (WABO), and Ed Chin (SEAW).*

The following diagram illustrates a broad overview of the design procedure of ACI 318 Chapter 17:

### HOLDOWN ANCHOR IN CONCRETE DESIGN FLOW

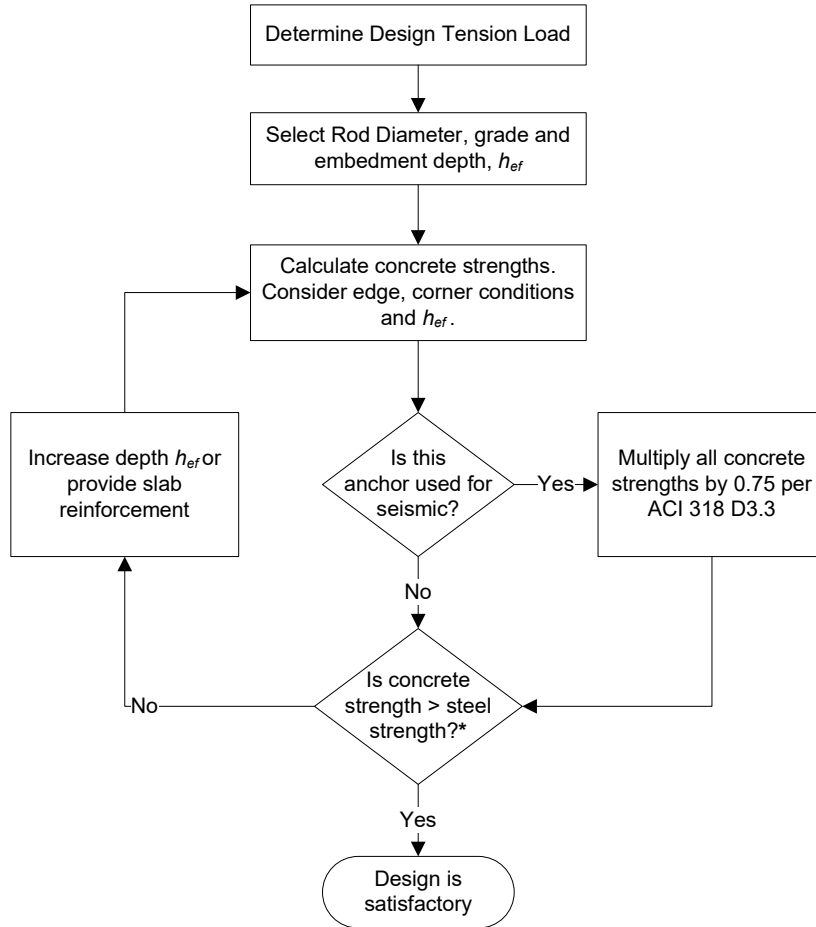

**Anchor Reinforcement Detailing:** In Chapter 17, when seismic design loads are used and concrete strength controls, it is required to provide reinforcing to resist the design strength of the anchor rod per ACI 318 17.2.3.4.4. This minimum concrete thickness required will vary by anchor rod size and grade. See sample details.

### Sample Detail #1

When slabs are less than 14 inches thick, anchors in the field of slab usually do not have adequate concrete capacity so reinforcing will be required. Due to the limited concrete thickness, development of the rebar above and below the breakout surface is not possible. However, since shear rail reinforcing, by design, is immediately developed under the head and above the rail it can be used in these cases. Care must be taken to use stud and rail spacings that allow for the large diameter heads (10 x stud area). Also the rail chair heights need to accommodate the crossing of orthogonal rails. The use of a minimum of four studs per rail provides adequate support for secure field placement.

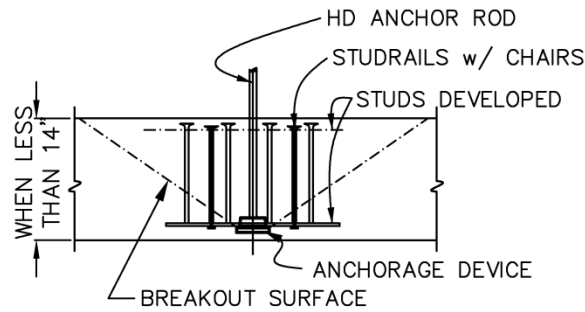

**SECTION**  
**ELEVATED SLAB**  
 NTS

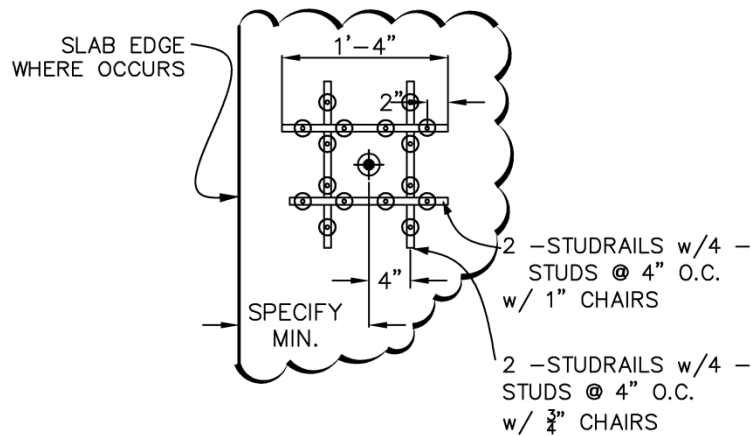

**PLAN VIEW**  
**ELEVATED SLAB**  
 NTS

## SAMPLE DETAIL 1

### Sample Detail #2

Anchors in the field of thicker slabs may develop the rebar hook development length “ $l_{dh}$ ” on each side of the breakout surface. If the vertical legs are sloped perpendicular to the breakout surface and a seismic hook is used at the ends, a minimum 14 inch thick slab or a 16 inch footing can be reinforced in this manner.

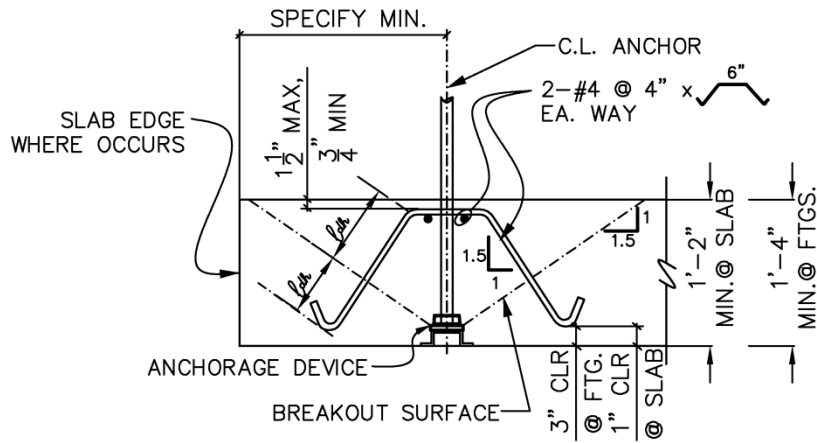

### SAMPLE DETAIL 2



### Sample Detail #3

Anchors near slab or footing edges are usually controlled by one of the concrete modes of failure in ACI 318 Chapter 17 and thus will required reinforcing. When wood frame shear walls are parallel to the slab edge, “side breakout” mode will always govern and therefore reinforcing will be required. Anchoring the rebar is the key to proper detailing when there is limited concrete space. This detail will work in thicker slabs and footings. Shear rail reinforcing could be used for sections thinner than shown.

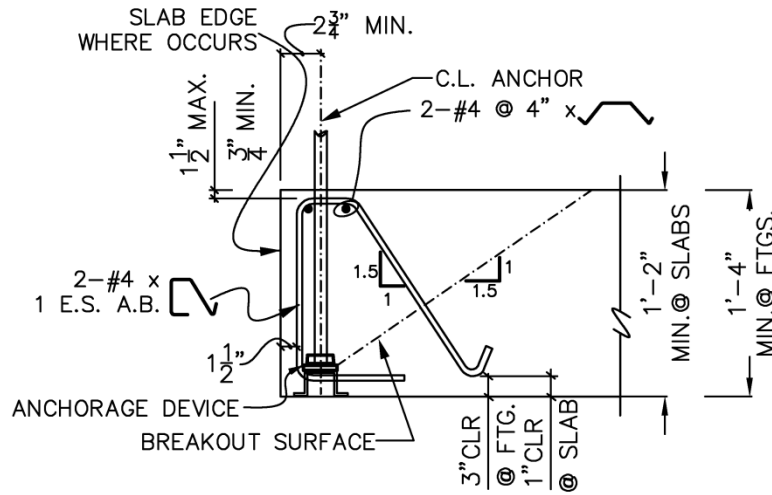

**SAMPLE DETAIL 3**